

# SPECIFICATION

## 1. PHYSICAL DIMENSION(UNIT: m/m):

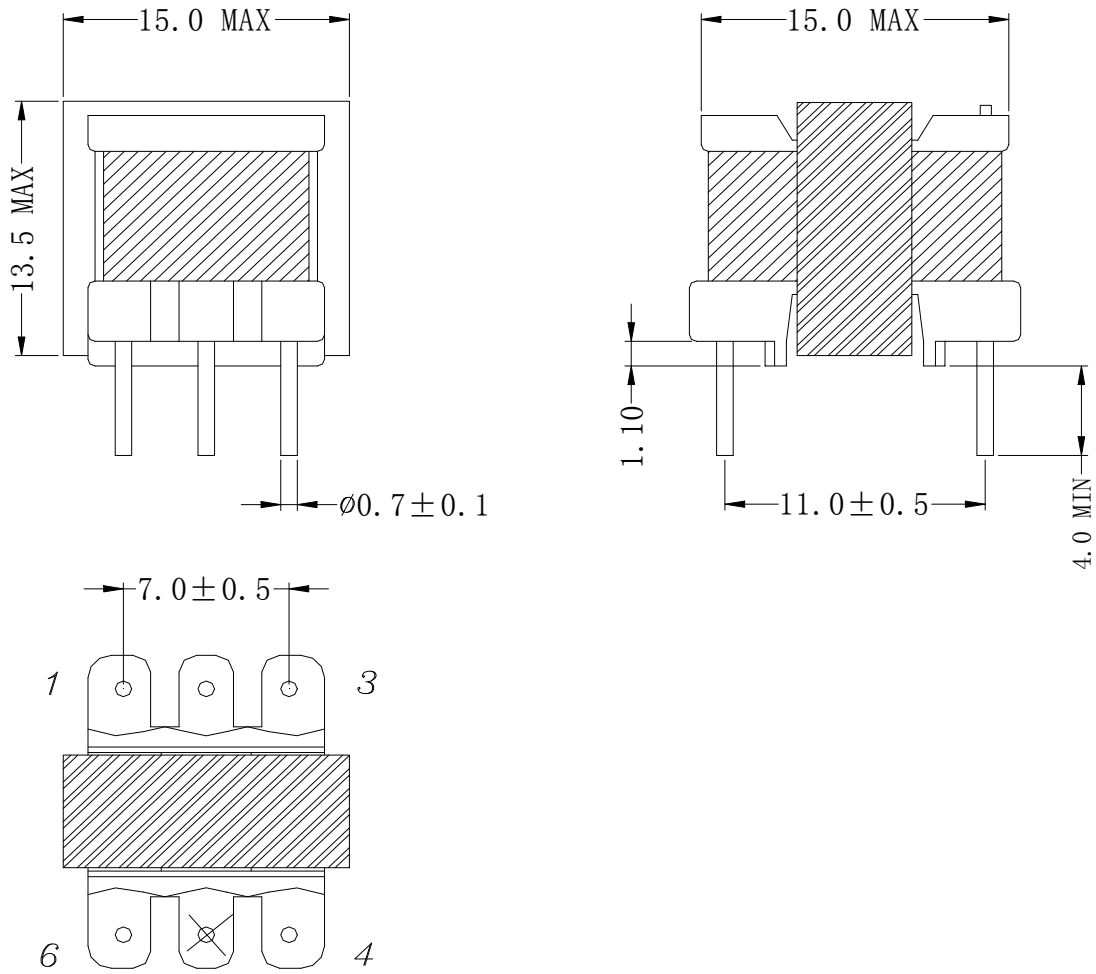

※DIMENSIONS WITHOUT TOLERANCE ARE APPROX  
 ※DIMENSION DOES NOT INCLUDE SOLDER USED ONCOILS

**LEAD FREE**

\*Note:PIN5 should be cut off

DIM	A	B	C	D	E	F	G	H				
SPEC												
						DESCRIPTION			TRANSFORMER			
						Customer P/N						
						FERRIWO P/N			FWPTEI14V372M			
SPEC. NO.	PS-3001-002				PREPARED			APPROVED				

# SPECIFICATION

## 2.WINDING TABLE:

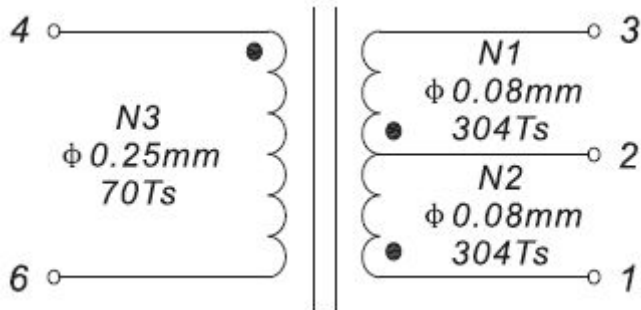

## 3.WINDING:

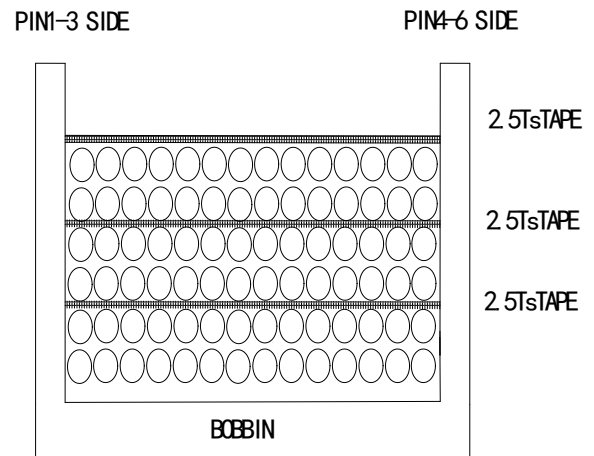

## 4.WINDING TABLE:

Winding NO.	Margin Tape	PIN	Wire & Wire Copper	Turns	Winding Type	Tape Layer	Tube
N1	0	2~3			Compact	2.5	0
N2	0	1~2			Compact	2.5	0
N3	0	4~6			Compact	2.5	0

### NOTE:

1. Pin 1 should be outside when the bobbin insert into the winding machine。
1. Products should be vacuum impregnation
  - \*VARNISH RATIO: 1:1
  - \*VACUUM TIME: 15~20minutes
  - \*BAKED TEMPERATURE :  $120^{\circ}C \pm 10^{\circ}C$  , 1~1.5hours

**LEAD FREE**

FERRIWO

DESCRIPTION	TRANSFORMER
Customer P/N	
FERRIWO P/N	FWPTEI14V372M

SPEC. NO.	PS-3001-002	PREPARED	APPROVED
-----------	-------------	----------	----------

# SPECIFICATION

## 5. ELECTRONICAL CHARACTERISTIC:

TEST CONDITION : TEMPERATURE AT 25°C

HUMIDITY AT 65 ±5% RH

TEST ITEM	TEST CONDITION	RESULT
INDUCTANCE CH-3250	@1.0KHz,0.3V (1~3) (4~6)	245.0mH±20% 3.7mH±20%
D.C.R CH-502	(1~2) (2~3) (4~6)	28.0Ω±15% 25.0Ω±15% 1.1Ω MAX
HI-POT TEST CH-9052	@ 1mA 1SEC (AC)	P<->S 0.5KV P、S<->CORE 0.5KV

**LEAD FREE**

**FERRIWO**

DESCRIPTION

TRANSFORMER

Customer P/N

FERRIWO P/N

FWPTEI14V372M

SPEC. NO.

PS-3001-002

PREPARED

APPROVED

# SPECIFICATION

## 6. MATERIAL LIST :

ITEM		MATERIAL	SUPPLIER OR MANUFACTURER	TEMPRATING
1	CORE	Z11 OR EQUIVALENT	HAINING FERRIWO ELECTRONICS CO., LTD.	
2	BOBBIN	T375J OR EQUIVALENT	HAINING FERRIWO ELECTRONICS CO., LTD.	150°C
3	WIRE	UEW	PACIFIC ELECTRIC WIRE&CABLE(SHENZHEN) CO. LTD UL NO E84081	130°C
4	TAPE	CT280	YAHUA STICKING TAPE CO.,LTD UL NO E165111	130°C
5	VARNISH	R-1038	ZHEJIANG RONGTAI TECHNICAL INDUSTRY CO.,LTD	130°C
6	Flux	TF9100	LINAN GUITONG CHEMICAL TECHNICAL CO.,LTD	
7	Tin	Sn99.3Cu0.7	HAINING ZHUCHANG METAL FOIL CO;LTD	

**LEAD FREE**



DESCRIPTION

TRANSFORMER

Customer P/N

FERRIWO P/N

FWPTEI14V372M

SPEC. NO.

PS-3001-002

PREPARED

APPROVED